

SET-3**Series QQBRR/3**प्रश्न-पत्र कोड
Q.P. Code **31/3/3**

रोल नं.

Roll No.

--	--	--	--	--	--	--	--

परीक्षार्थी प्रश्न-पत्र कोड को उत्तर-पुस्तिका के मुख-पृष्ठ पर अवश्य लिखें ।

Candidates must write the Q.P. Code on the title page of the answer-book.

- कृपया जाँच कर लें कि इस प्रश्न-पत्र में मुद्रित पृष्ठ **15** हैं ।
- प्रश्न-पत्र में दाहिने हाथ की ओर दिए गए प्रश्न-पत्र कोड को परीक्षार्थी उत्तर-पुस्तिका के मुख-पृष्ठ पर लिखें ।
- कृपया जाँच कर लें कि इस प्रश्न-पत्र में **15** प्रश्न हैं ।
- कृपया प्रश्न का उत्तर लिखना शुरू करने से पहले, उत्तर-पुस्तिका में प्रश्न का क्रमांक अवश्य लिखें ।
- इस प्रश्न-पत्र को पढ़ने के लिए 15 मिनट का समय दिया गया है । प्रश्न-पत्र का वितरण पूर्वाह्न में 10.15 बजे किया जाएगा । 10.15 बजे से 10.30 बजे तक छात्र केवल प्रश्न-पत्र को पढ़ेंगे और इस अवधि के दौरान वे उत्तर-पुस्तिका पर कोई उत्तर नहीं लिखेंगे ।
- Please check that this question paper contains **15** printed pages.
- Q.P. Code given on the right hand side of the question paper should be written on the title page of the answer-book by the candidate.
- Please check that this question paper contains **15** questions.
- **Please write down the serial number of the question in the answer-book before attempting it.**
- 15 minute time has been allotted to read this question paper. The question paper will be distributed at 10.15 a.m. From 10.15 a.m. to 10.30 a.m., the students will read the question paper only and will not write any answer on the answer-book during this period.

विज्ञान SCIENCE

निर्धारित समय : 2 घण्टे

Time allowed : 2 hours

अधिकतम अंक : 40

Maximum Marks : 40

31/3/3

1



P.T.O.



सामान्य निर्देश :

निम्नलिखित निर्देशों को बहुत सावधानी से पढ़िए और उनका सख्ती से पालन कीजिए :

- (i) इस प्रश्न-पत्र में कुल 15 प्रश्न हैं । सभी प्रश्न अनिवार्य हैं ।
- (ii) यह प्रश्न-पत्र तीन खण्डों में विभाजित किया गया है – क, ख एवं ग ।
- (iii) खण्ड क – प्रश्न संख्या 1 से 7 तक लघु-उत्तरीय प्रकार के प्रश्न हैं । प्रत्येक प्रश्न 2 अंकों का है ।
- (iv) खण्ड ख – प्रश्न संख्या 8 से 13 भी लघु-उत्तरीय प्रकार के प्रश्न हैं । प्रत्येक प्रश्न 3 अंकों का है ।
- (v) खण्ड ग – प्रश्न संख्या 14 और 15 प्रकरण-आधारित प्रश्न हैं । प्रत्येक प्रश्न 4 अंकों का है ।
- (vi) कुछ प्रश्नों में आंतरिक चयन प्रदान किया गया है । इस प्रकार के प्रश्नों में केवल एक ही विकल्प का उत्तर दीजिए ।

खण्ड क

1. (क) अनुमतांक 1100 W का कोई विद्युत् तापक 220 V पर प्रचालित किया गया है । परिकलित कीजिए (i) तापक का प्रतिरोध, तथा (ii) तापक द्वारा ली गई विद्युत् धारा । 2

अथवा

- (ख) नीचे दिए गए विद्युत् परिपथ का तुल्य प्रतिरोध परिकलित कीजिए : 2

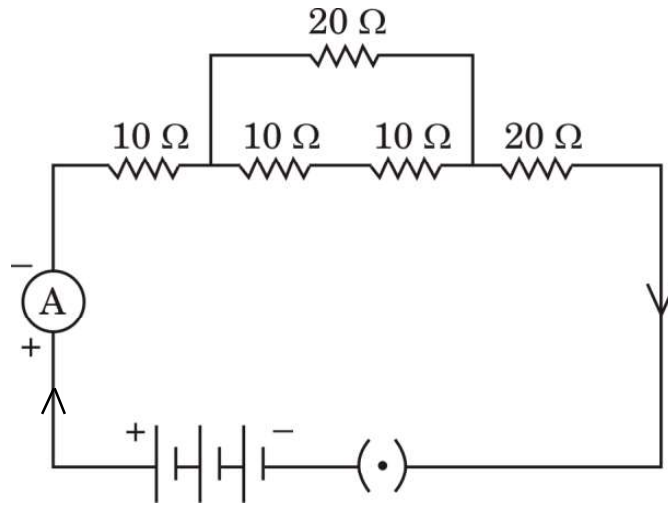

2. आधुनिक आवर्त सारणी में (i) किसी समूह में ऊपर से नीचे जाने पर, तथा (ii) किसी आवर्त में बाईं ओर से दाईं ओर जाने पर तत्त्वों की इलेक्ट्रॉन त्यागने की प्रवृत्तियों की तुलना कीजिए । 2



General Instructions :

Read the following instructions very carefully and strictly follow them :

- (i) This question paper comprises **15** questions. **All** questions are compulsory.
- (ii) This question paper is divided into **three** sections – **A, B** and **C**.
- (iii) **Section A** – Questions No. **1** to **7** are short answer type questions. Each question carries **2** marks.
- (iv) **Section B** – Questions No. **8** to **13** are also short answer type questions. Each question carries **3** marks.
- (v) **Section C** – Questions No. **14** and **15** are case-based questions. Each question carries **4** marks.
- (vi) Internal choices have been provided in some questions. Only one of the alternatives has to be attempted.

SECTION A

1. (a) An electric heater rated 1100 W operates at 220 V. Calculate
(i) its resistance, and (ii) the current drawn by it. 2

OR

- (b) Calculate the equivalent resistance of the following electric circuit : 2

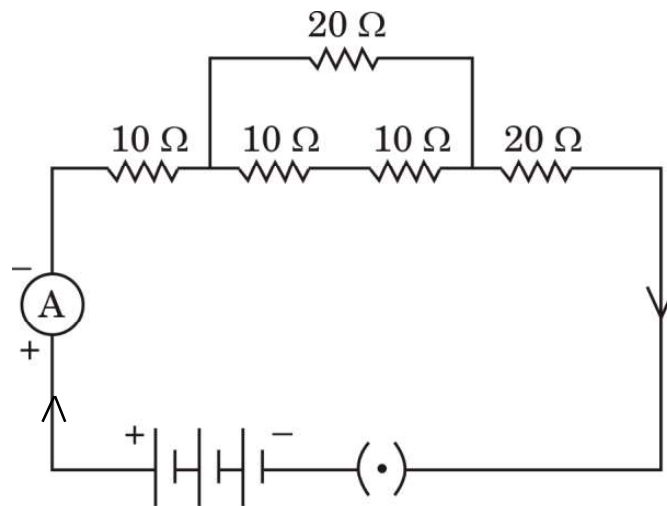

2. In the modern periodic table, compare the tendency of the elements to lose electrons while moving (i) down a group, and (ii) from left to right in a period. 2

31/3/3



3. ब्यूटेन के दो संरचनात्मक समावयवों की संरचना खींचिए । 2

4. (क) डिस्पोजेबल कुल्हड़ों (मिट्टी के पात्र) और डिस्पोजेबल कागज़ के कपों दोनों का उपयोग प्लास्टिक के डिस्पोजेबल कपों के विकल्प के रूप में किया जा रहा है । इन दोनों में से किसे प्लास्टिक के कपों के बेहतर विकल्प के रूप में माना जा सकता है और क्यों ? 2

अथवा

(ख) जैव आवर्धन द्वारा मानव पर सबसे अधिक प्रतिकूल प्रभाव पड़ रहा है । इसका कारण लिखिए । खाद्य पदार्थों (फलों और सब्जियों) की सामान्य धुलाई से जैव आवर्धन के प्रभाव को कम क्यों नहीं किया जा सकता है ? 2

5. (क) दिए गए आरेख में, उस भाग का नाम लिखिए (i) जहाँ परागकण बनते हैं, और (ii) जहाँ परागकणों का स्थानान्तरण होता है ।

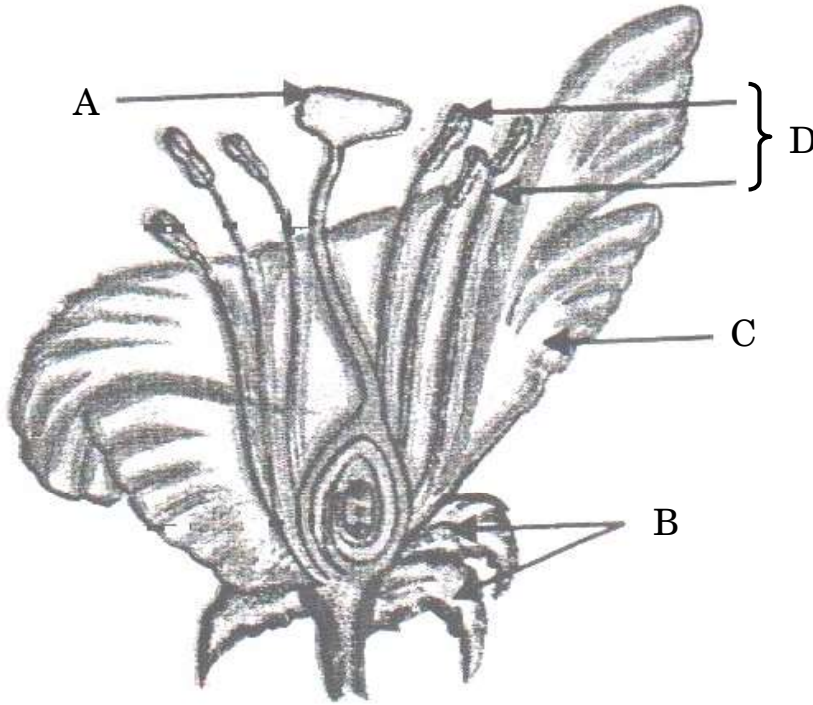

(ख) निषेचन के पश्चात् बीजाण्ड और अण्डाशय का क्या होता है ? 2



3. Draw two structural isomers of butane. 2

4. (a) Kulhads (disposable cups made of clay) and disposable paper cups both are used as an alternative for disposable plastic cups. Which one of these two can be considered as a better alternative to plastic cups and why? 2

OR

(b) Human beings are most adversely affected by the Biological Magnification. State the reason. Why can ordinary washing of the edibles (fruits and vegetables) not reduce the effect of biological magnification? 2

5. (a) In the given diagram, name the parts where (i) pollen grains are produced, and (ii) pollen grains are transferred.

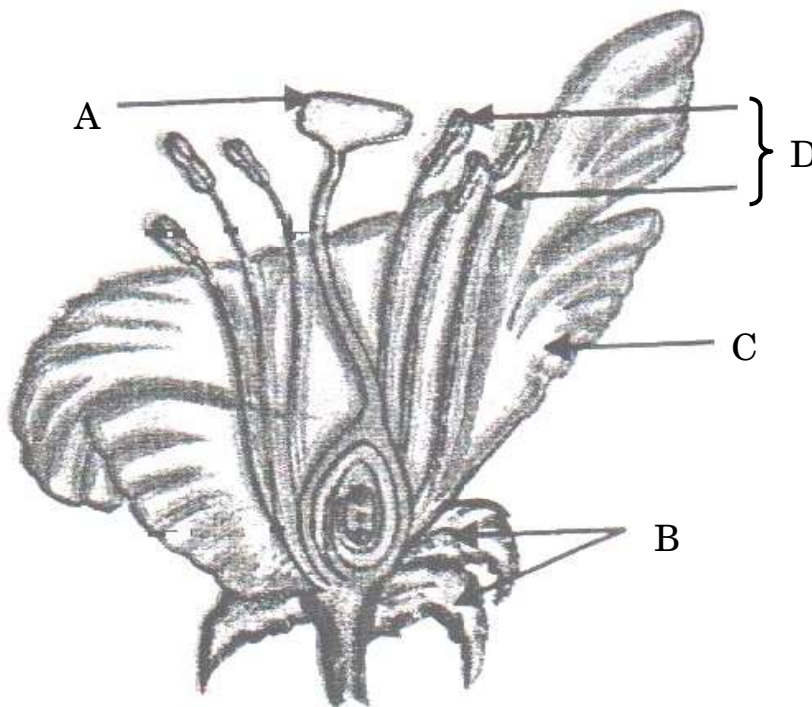

(b) What happens to ovule and ovary after fertilisation? 2

31/3/3

5



P.T.O.

6. मानव जनसंख्या के साइज़ को नियंत्रित करने की कोई दो गर्भनिरोधी विधियाँ सुझाइए और उनकी व्याख्या कीजिए । 2

7. (क) मेंडल ने स्थूल रूप से दिखाई देने वाले दो विपर्यासी (विकल्पी) लक्षणों वाले मटर के पौधों के बीच संकरण कराने पर यह पाया कि F_1 संतति में प्राप्त पौधों में कोई भी बीचों-बीच (मिश्रित) लक्षणों वाला पौधा नहीं है । मेंडल के इस प्रेक्षण के कारण की व्याख्या कीजिए । 2

अथवा

(ख) इस कथन की पुष्टि कीजिए कि “शिशु का लिंग निर्धारण इस तथ्य पर आधारित है कि वह अपने पिता से क्या वंशानुगत करता है” । 2

खण्ड ख

8. नीचे दी गई सारणी में कुछ तत्त्व किसी विशेष पैटर्न में व्यवस्थित किए गए हैं :

sa (do)	re (re)	ga (mi)	ma (fa)	pa (so)	da (la)	ni (ti)
H	Li	Be	B	C	N	O
F	Na	Mg	Al	Si	P	S
Cl	K	Ca	Cr	Ti	Mn	Fe
Co और Ni	Cu	Zn	Y	In	As	Se
Br	Rb	Sr	Ce और La	Zr	-	-

उस आवर्त नियम को पहचानिए जिससे यह सारणी संबद्ध है । उपर्युक्त आवर्त नियम की दो प्रमुख विशेषताओं और दो विसंगतियों की सूची बनाइए । 3

9. मेंडल के प्रयोगों ने यह किस प्रकार दर्शाया कि लक्षण स्वतंत्र रूप से वंशानुगत होते हैं ? व्याख्या कीजिए । 3

10. (क) अपमार्जक (अपघटक) क्या हैं ? मृदा की प्राकृतिक पुनःपूर्ति में अपमार्जकों की भूमिका का उल्लेख कीजिए ।

(ख) प्लास्टिक अपशिष्ट के अपघटन में अपमार्जक (अपघटक) सहायक क्यों नहीं होते हैं ? 3

31/3/3



6. Suggest any two contraceptive methods to control the size of human population and explain them. 2

7. (a) Mendel crossed two pea plants with visible contrasting characteristics and found that there were no half-way characteristics in the plants of F_1 progeny. Explain the reason for this observation of Mendel. 2

OR

(b) Justify the statement "Sex of the children will be determined by what they inherit from their father". 2

SECTION B

8. In the following table, some elements have been arranged in a certain pattern :

sa (do)	re (re)	ga (mi)	ma (fa)	pa (so)	da (la)	ni (ti)
H	Li	Be	B	C	N	O
F	Na	Mg	Al	Si	P	S
Cl	K	Ca	Cr	Ti	Mn	Fe
Co and Ni	Cu	Zn	Y	In	As	Se
Br	Rb	Sr	Ce and La	Zr	–	–

Identify the periodic law with which the given table is associated. List two important features and two anomalies of the above periodic law. 3

9. How do Mendel's experiments show that the traits are inherited independently ? Explain. 3

10. (a) What are decomposers ? State the role of decomposers in the natural replenishment of the soil.
(b) Why are decomposers not helpful in decomposing the plastic waste ? 3

31/3/3



11. (क) कारण का उल्लेख कीजिए, ऐसा क्यों है कि
- कार्बन के यौगिकों के गलनांक और क्वथनांक निम्न होते हैं ।
 - कार्बन के यौगिक विद्युत् का चालन नहीं करते हैं ।
 - कार्बन केवल सहसंयोजी यौगिक बना सकता है ।

3

अथवा

- (ख) समजातीय श्रेणी किसे कहते हैं ? किसी समजातीय श्रेणी के दो क्रमागत सदस्यों के आण्विक द्रव्यमानों के बीच अन्तर ज्ञात कीजिए । उल्लेख कीजिए कि कार्बन के यौगिकों की किसी समजातीय श्रेणी में आण्विक द्रव्यमान में वृद्धि होने पर निम्नलिखित गुणधर्मों में किस प्रकार का विचरण होता है :

3

- गलनांक और क्वथनांक
- रासायनिक गुणधर्म

12. (क) धारावाही वृत्ताकार लूप (पाश) द्वारा उत्पन्न चुम्बकीय क्षेत्र रेखाओं का पैटर्न खींचते हुए लूप में प्रवाहित विद्युत् धारा की दिशा तथा चुम्बकीय क्षेत्र रेखाओं की दिशा भी दर्शाइए ।
- (ख) उस नियम को लिखिए जिसका उपर्युक्त प्रकरण में चुम्बकीय क्षेत्र रेखाओं की दिशा ज्ञात करने में उपयोग किया जा सकता है ।

3

13. (क) नीचे दिए गए आरेख में कुण्डली – 1 श्रेणीक्रम में बैटरी और प्लग कुंजी से संयोजित है जबकि कुण्डली – 2 एक गैल्वेनोमीटर से संयोजित है ।

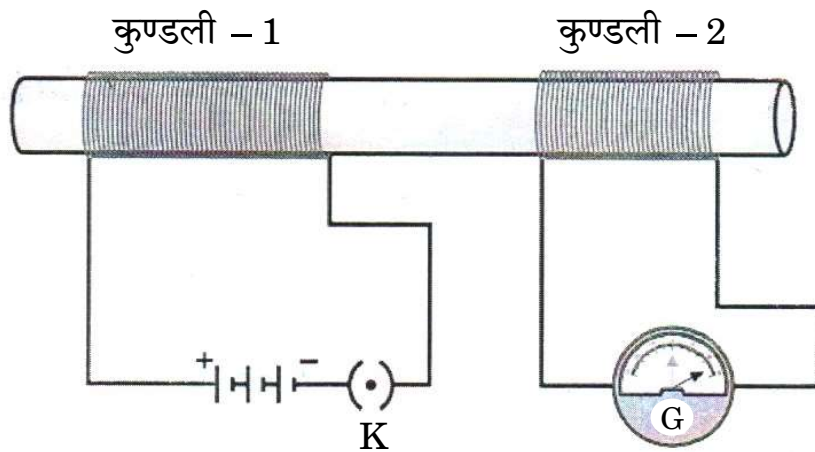

- ऐसा क्यों है कि गैल्वेनोमीटर में विक्षेपण केवल उसी समय होता है जब कुंजी (K) को प्लग में लगा रहे होते हैं और उस समय नहीं होता जब परिपथ में स्थायी धारा प्रवाहित होने लगती है ?

31/3/3

8



11. (a) State the reason why
- (i) carbon compounds have low melting and boiling points.
 - (ii) carbon compounds do not conduct electricity.
 - (iii) carbon can form only covalent compounds.

3

OR

- (b) What is a homologous series ? Find the difference in molecular mass between the two consecutive members of a homologous series. State how in a homologous series of carbon compounds the following properties vary with increase in molecular mass :

3

- (i) Melting and boiling points
- (ii) Chemical properties

12. (a) Draw the pattern of magnetic field lines produced by a current carrying circular loop showing the direction of current in the loop and the direction of the magnetic field lines.

- (b) State the rule which can be applied to know the direction of magnetic field lines in the above case.

3

13. (a) In the diagram given below, Coil – 1 is connected in series with a battery and a plug key while Coil – 2 is connected with a galvanometer.

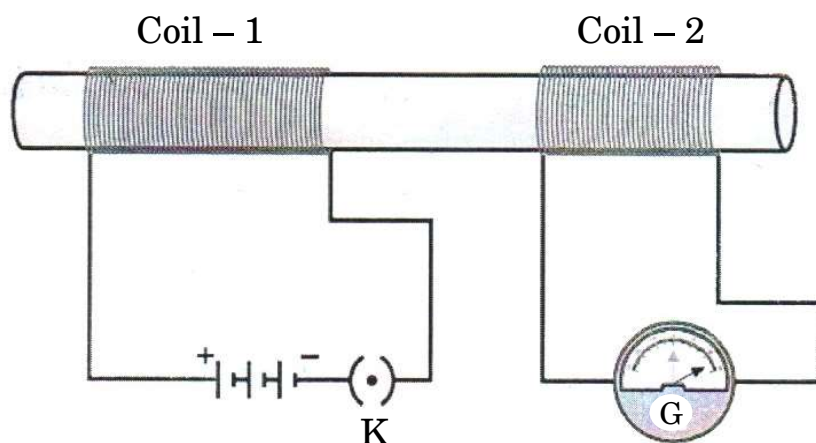

- (i) Why does the galvanometer show deflection only when the key (K) is plugged in and not when a steady current starts flowing in the circuit ?

31/3/3

9



P.T.O.

- (ii) उस समय गैल्वेनोमीटर में क्या प्रेक्षण किया जाता है, जब प्लग से कुंजी को निकाला जाता है ?
- (iii) इस क्रियाकलाप के प्रेक्षण के आधार पर निकलने वाला निष्कर्ष लिखिए ।

3

अथवा

(ख) नीचे दिए गए आरेख में, सरल विद्युत् मोटर को दर्शाया गया है :

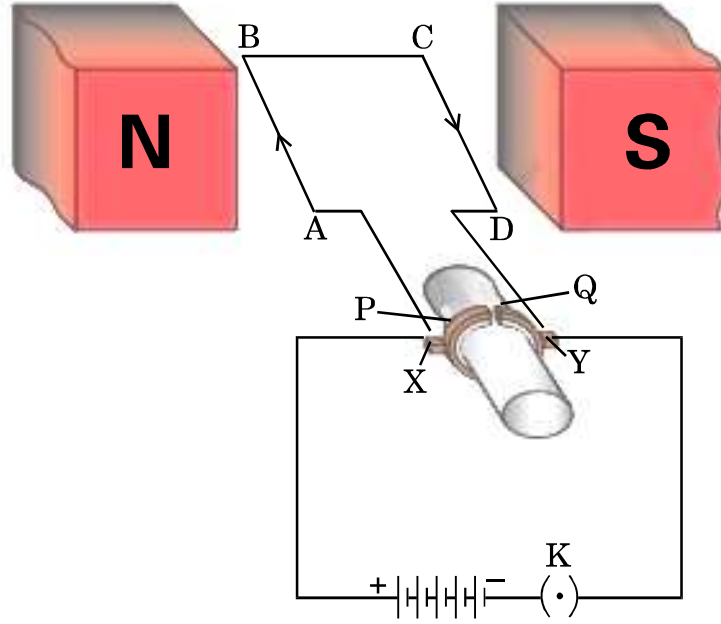

आरेख में दर्शाए अनुसार, कुण्डली ABCD में विद्युत् धारा का प्रवाह भुजा AB में A से B की ओर तथा भुजा CD में C से D की ओर है ।

- (i) भुजा AB और भुजा CD पर लगने वाले बल की दिशाओं का उल्लेख कीजिए ।
- (ii) विद्युत् मोटर के उस भाग को पहचानिए और उसका नाम लिखिए जो कुण्डली ABCD में विद्युत् धारा के प्रवाह की दिशा उत्क्रमित कर देता है ।
- (iii) कुण्डली ABCD में विद्युत् धारा के प्रवाह की दिशा उत्क्रमित होने के पश्चात् भुजा AB और भुजा CD पर लगने वाले बलों की दिशा लिखिए ।
- (iv) किसी चुम्बकीय क्षेत्र में स्थित धारावाही चालक पर लगने वाले बल की दिशा निर्धारित करने वाले नियम का नाम लिखिए ।

3

31/3/3

10



- (ii) What is observed in the galvanometer, when the key is plugged out ?
- (iii) State the conclusion based on the observation of this activity.

3

OR

- (b) In the figure given below, a simple electric motor is shown :

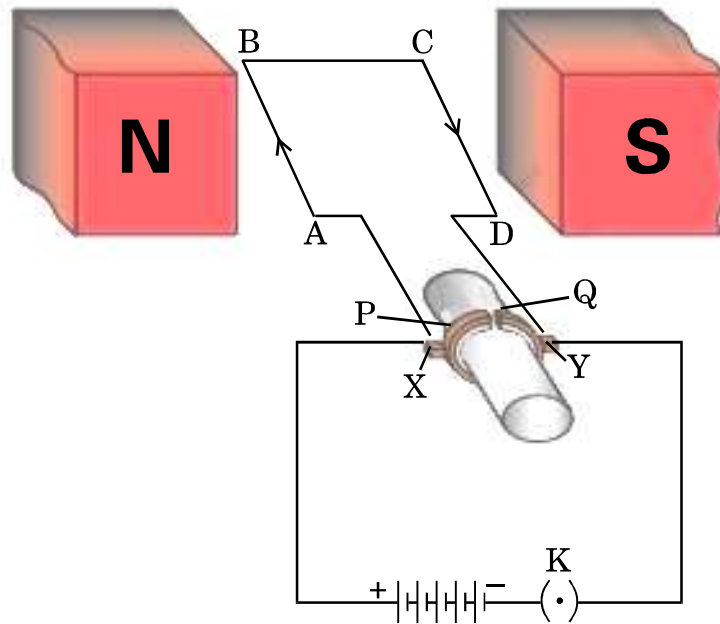

As shown in the figure, the current in the coil ABCD flows from A to B in the arm AB and C to D in the arm CD.

- (i) State the directions in which the arms AB and CD will experience a force.
- (ii) Identify the part of the electric motor that reverses the flow of current in the coil ABCD and write its name.
- (iii) After the reversal of flow of current in the coil ABCD, state the directions in which the arms AB and CD will experience a force.
- (iv) Name the rule which is applied to determine the direction of force on a current carrying conductor placed in a magnetic field.

3



खण्ड ग

इस खण्ड में 2 प्रकरण-आधारित प्रश्न (14 और 15) हैं। प्रत्येक प्रकरण में 3 उप-भाग (क), (ख) और (ग) हैं। भाग (क) और (ख) अनिवार्य हैं। भाग (ग) में आंतरिक चयन प्रदान किया गया है।

14. नीचे दिए गए विद्युत् परिपथ का अध्ययन कीजिए जिनमें प्रतिरोधक तीन भुजाओं A, B और C में व्यवस्थित हैं :

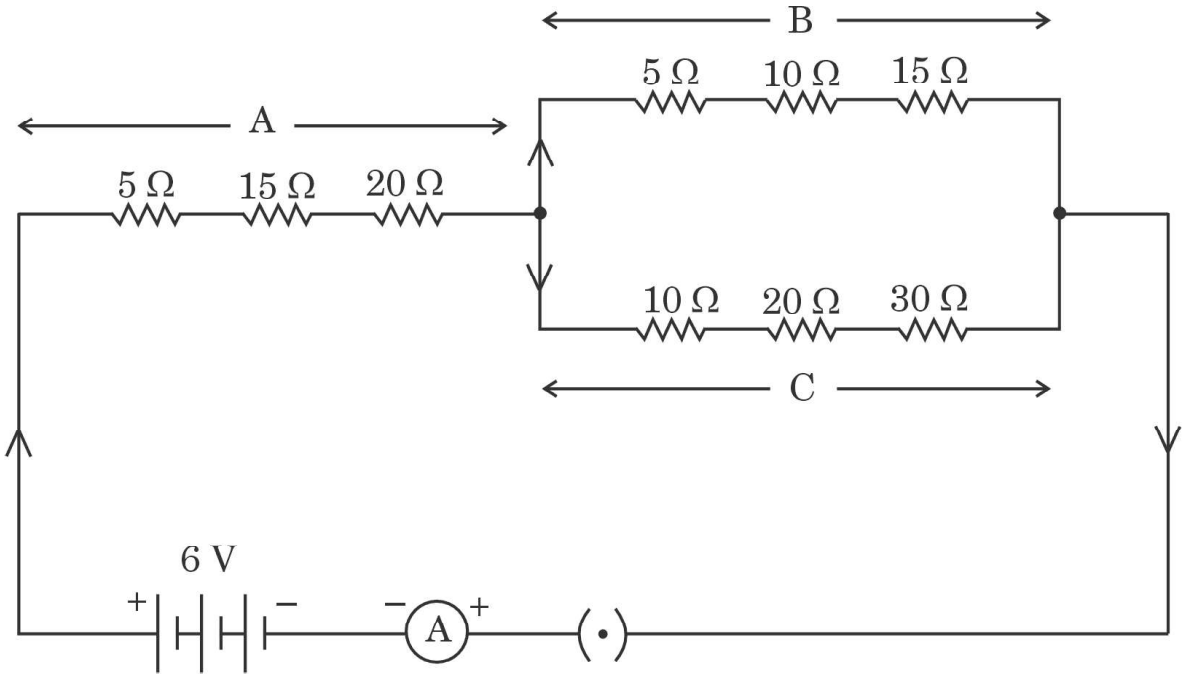

- | | |
|---|---|
| (क) भुजा C का तुल्य प्रतिरोध ज्ञात कीजिए। | 1 |
| (ख) भुजा B और भुजा C के पार्श्व संयोजन का तुल्य प्रतिरोध परिकलित कीजिए। | 1 |
| (ग) (i) ऐमीटर में प्रवाहित धारा निर्धारित कीजिए। | 2 |

अथवा

- | | |
|--|---|
| (ii) यदि इस परिपथ से भुजा B को हटा दिया जाए, तो ऐमीटर में प्रवाहित धारा निर्धारित कीजिए। | 2 |
|--|---|



SECTION C

This section has **2** case-based questions (**14** and **15**). Each case is followed by **3** sub-questions (a), (b) and (c). Parts (a) and (b) are **compulsory**. However, an internal choice has been provided in Part (c).

14. Study the following electric circuit in which the resistors are arranged in three arms A, B and C :

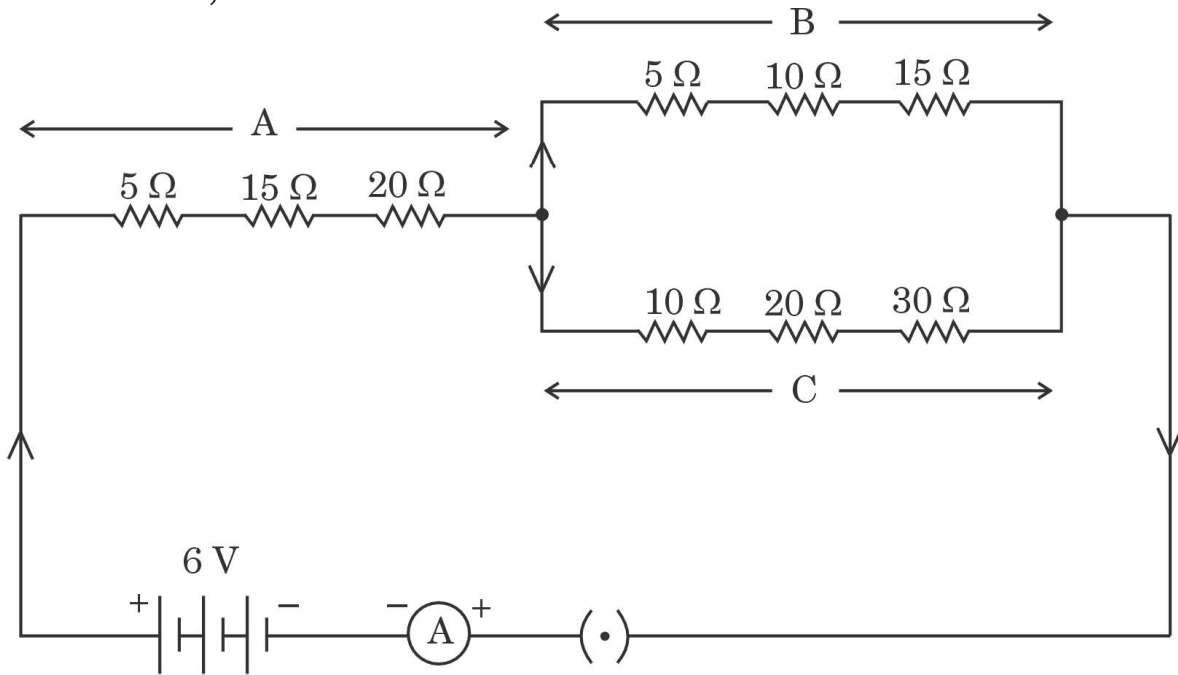

- | | | |
|-----|--|---|
| (a) | Find the equivalent resistance of arm C. | 1 |
| (b) | Calculate the equivalent resistance of the parallel combination of the arms B and C. | 1 |
| (c) | (i) Determine the current that flows through the ammeter. | 2 |

OR

- | | | |
|------|---|---|
| (ii) | Determine the current that flows in the ammeter when the arm B is withdrawn from the circuit. | 2 |
|------|---|---|

31/3/3

13



P.T.O.

15. वह विधा जिसके द्वारा विभिन्न जीव जनन करते हैं, उनकी शारीरिक अभिकल्प (डिज़ाइन) पर निर्भर करती है। अलैंगिक जनन में, एकल व्यष्टि जनक अपनी संतति (उपज) उत्पन्न करते हैं और युग्मनज सम्मिलित नहीं होते हैं। यह विधि अनुकूल परिस्थितियों में संतति की संख्या में तीव्र वृद्धि करने का एक सामान्य साधन है। अलैंगिक जनन मुख्यतः एककोशिक जीवों, कुछ पौधों और कुछ सरल बहुकोशिक जन्तुओं में होता है।

- (क) उस जीव का नाम लिखिए जिसमें द्विखण्डन एक निर्धारित तल में होता है। इस जीव के कारण होने वाले रोग का नाम भी लिखिए। 1
- (ख) जब 'ब्रायोफिलम' की पत्तियाँ मृदा पर गिरती हैं तो नए पौधे में विकसित हो जाती हैं जबकि केले के पौधे की पत्तियाँ ऐसा करने योग्य नहीं होतीं। क्यों? 1
- (ग) (i) हाइड्रा में मुकुलन की प्रक्रिया की व्याख्या कीजिए। 2

अथवा

- (ii) क्या होता है जब
- (I) स्पाइरोगायरा तन्तु विकसित होकर काफी लम्बा हो जाता है, और
- (II) कोई बीजाणुधानी राइज़ोपस में विकसित होकर फट जाती है? 2



15. The modes by which various organisms reproduce depend on the body design of the organisms. In asexual reproduction, a single individual parent produces offsprings without the involvement of gametes. This method is a common means of increasing the offsprings rapidly under favourable conditions. Asexual reproduction occurs mostly in unicellular organisms, some plants and certain simple multicellular animals.

- (a) State the name of the organism in which binary fission takes place in a definite orientation. Also name the disease caused by this organism. 1
- (b) Leaves of 'Bryophyllum' when they fall on the soil develop into new plants whereas a banana leaf will not be able to do so. Why? 1
- (c) (i) Explain the process of budding in Hydra. 2

OR

- (ii) What happens when
- (I) a spirogyra filament matures and attains a considerable length, and
- (II) a sporangia in Rhizopus bursts on maturation? 2

31/3/3

15



Strictly Confidential: (For Internal and Restricted use only)
Class : X Secondary School Term II Examination, 2022
Marking Scheme – Science SUBJECT CODE -086
(PAPER CODE –31/3/2)

General Instructions: -

1. You are aware that evaluation is the most important process in the actual and correct assessment of the candidates. A small mistake in evaluation may lead to serious problems which may affect the future of the candidates, education system and teaching profession. To avoid mistakes, it is requested that before starting evaluation, you must read and understand the spot evaluation guidelines carefully.
2. **“Evaluation policy is a confidential policy as it is related to the confidentiality of the examinations conducted, Evaluation done and several other aspects. Its’ leakage to public in any manner could lead to derailment of the examination system and affect the life and future of millions of candidates. Sharing this policy/document to anyone, publishing in any magazine and printing in News Paper/Website etc may invite action under IPC.”**
3. Evaluation is to be done as per instructions provided in the Marking Scheme. It should not be done according to one’s own interpretation or any other consideration. Marking Scheme should be strictly adhered to and religiously followed. **However, while evaluating, answers which are based on latest information or knowledge and/or are innovative, they may be assessed for their correctness otherwise and marks be awarded to them. In class-X, while evaluating two competency based questions, please try to understand given answer and even if reply is not from marking scheme but correct competency is enumerated by the candidate, marks should be awarded.**
4. The Head-Examiner must go through the first five answer books evaluated by each evaluator on the first day, to ensure that evaluation has been carried out as per the instructions given in the Marking Scheme. The remaining answer books meant for evaluation shall be given only after ensuring that there is no significant variation in the marking of individual evaluators.
5. Evaluators will mark(\surd) wherever answer is correct. For wrong answer ‘X’ be marked. Evaluators will not put right kind of mark while evaluating which gives an impression that answer is correct and no marks are awarded. **This is most common mistake which evaluators are committing.**
6. If a question has parts, please award marks on the right-hand side for each part. Marks awarded for different parts of the question should then be totalled up and written in the left-hand margin and encircled. This may be followed strictly.
7. If a question does not have any parts, marks must be awarded in the left-hand margin and encircled. This may also be followed strictly.
8. If a student has attempted an extra question, answer of the question deserving more marks should be retained and the other answer scored out.
9. No marks to be deducted for the cumulative effect of an error. It should be penalized only once.
10. A full scale of marks **40** has to be used. Please do not hesitate to award full marks if the answer deserves it.
11. Every examiner has to necessarily do evaluation work for full working hours i.e. 8 hours every day and evaluate 30 answer books per day in main subjects and 35 answer books per day in other subjects (Details are given in Spot Guidelines). This is in view of the reduced syllabus and number of questions in question paper.
12. Ensure that you do not make the following common types of errors committed by the Examiner in the past:-
 - Leaving answer or part thereof unassessed in an answer book.
 - Giving more marks for an answer than assigned to it.

- Wrong totalling of marks awarded on a reply.
 - Wrong transfer of marks from the inside pages of the answer book to the title page.
 - Wrong question wise totalling on the title page.
 - Wrong totalling of marks of the two columns on the title page.
 - Wrong grand total.
 - Marks in words and figures not tallying.
 - Wrong transfer of marks from the answer book to online award list.
 - Answers marked as correct, but marks not awarded. (Ensure that the right tick mark is correctly and clearly indicated. It should merely be a line. Same is with the X for incorrect answer.)
 - Half or a part of answer marked correct and the rest as wrong, but no marks awarded.
13. While evaluating the answer books if the answer is found to be totally incorrect, it should be marked as cross (X) and awarded zero (0) Marks.
14. Any unassessed portion, non-carrying over of marks to the title page, or totalling error detected by the candidate shall damage the prestige of all the personnel engaged in the evaluation work as also of the Board. Hence, in order to uphold the prestige of all concerned, it is again reiterated that the instructions be followed meticulously and judiciously.
15. The Examiners should acquaint themselves with the guidelines given in the Guidelines for spot Evaluation before starting the actual evaluation.
16. Every Examiner shall also ensure that all the answers are evaluated, marks carried over to the title page, correctly totalled and written in figures and words.
17. The Board permits candidates to obtain photocopy of the Answer Book on request in an RTI application and also separately as a part of the re-evaluation process on payment of the processing charges.

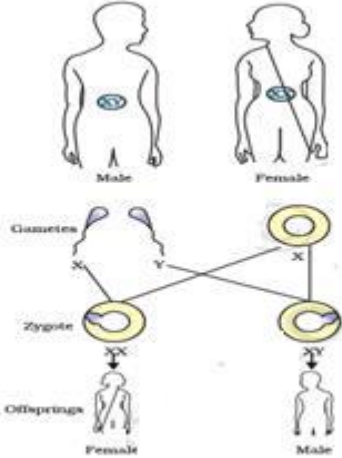
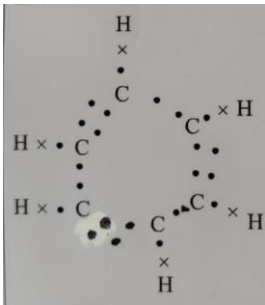

	 <p style="text-align: center;">(full credit for diagrammatic expression)</p>		2
3.	<ul style="list-style-type: none"> • Barrier method : Prevents the meeting of sperms with ova • Oral pills/Chemical method : Changes the hormonal balance in females so eggs are not released • Copper T or loop : to prevent pregnancy/to prevent fusion of male & female gametes • Surgical method : To block vas deferens in males or fallopian tube in females to prevent fertilization <p style="text-align: right;">(Any two)</p>	1+1	2
4.	<ul style="list-style-type: none"> • Electronic configuration of X : 2, 8, 8, 6 • Valency = 2 • Group of X= 6 • Period of X=4 	$\frac{1}{2}$ $\frac{1}{2}$ $\frac{1}{2}$ $\frac{1}{2}$	2
5.	<p>(a) Electron dot structure of benzene</p> 	1	

	<p>(b) Electron dot structure of ethane</p> <pre> H H × × • • H × • C • • C • × H • • × × H H </pre>	1	2
6.	<p>(a)</p> <ul style="list-style-type: none"> • Disposable paper cups. • Making of Kulhads on a large scale would result in the loss of fertile top soil. / Disposable paper cups can easily decompose and do not pollute the environment. <p style="text-align: center;">(or any other suitable answer)</p> <p style="text-align: center;">OR</p> <p>(b)</p> <ul style="list-style-type: none"> • Human beings occupy the top level in any food chain therefore maximum concentration of these chemicals get accumulated in our bodies. • Harmful chemicals or pesticides get absorbed from the soil by the plants along with water and minerals therefore ordinary washing cannot remove these harmful chemicals. 	1 1	2
7.	<p>(a) P (Power) = V (Potential difference) \times I (Current) Here $P = 1100$ W, $V = 220$ V, $I = ?$, $R = ?$</p> $P = \frac{V^2}{R}$ <p>(i) $R = \frac{V^2}{P}$</p> $= \frac{220^2 \text{ V} \times 220 \text{ V}}{1100 \text{ W}}$ $= 44 \Omega$ <p>(ii) $I = \frac{V}{R}$</p> $I \text{ (Current)} = \frac{V}{R} = \frac{220 \text{ V}}{44 \Omega} = 5 \text{ A}$ <p style="text-align: center;">(Accept any other alternative method)</p> <p style="text-align: center;">OR</p>	$\frac{1}{2}$ $\frac{1}{2}$ $\frac{1}{2}$	2

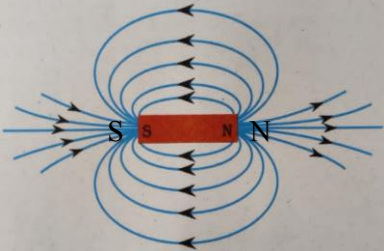
	(iii) Arm AB upward, Arm CD downward/Direction of force will get Reversed (iv) Fleming's left-hand rule	$\frac{1}{2}$ $\frac{1}{2}$	3
10.	(a) • Field lines around a bar magnet.  • Position of North pole, South pole- to be marked in the diagram • Field is strongest where lines are crowded / at Poles / or indicated in the diagram. (b) If two field lines cross each other then at the point of intersection, the compass needle would point towards two directions which is not possible.	1 $\frac{1}{2}$ $\frac{1}{2}$	3
11.	• Newland's Law of Octaves • Important features : 1. The elements were arranged in the order of their increasing atomic mass. 2. Every eighth element has properties similar to the first element. • Anomalies : 1. It was assumed that only 56 elements existed in nature and new elements would not be discovered in future. 2. Unlike elements were put in the same slot/note. <p style="text-align: right;">(Or any other)</p>	1 $\frac{1}{2}$ $\frac{1}{2}$ $\frac{1}{2}$ $\frac{1}{2}$	3
12.	(a) (i) The forces of attraction between the molecules are weak. (ii) Bonding in carbon compounds does not give rise to any charged particles. (iii) Carbon only shares electrons with other atoms. It is not able to lose four electrons or gain four electrons. <p style="text-align: center;">OR</p> (b) • A series of compounds in which some functional groups substitute for hydrogen in a carbon chain / the consequent members differ by $-CH_2$ unit (14 u) • Difference of $CH_2 = 12u + 2u = 14u$ (i) Melting and boiling points increase with increase in molecular mass. (ii) Chemical properties, determined by the functional group remain same in a homologous series.	1 1 1 1 1 $\frac{1}{2}$ $\frac{1}{2}$	3



13.	<p>(a) Since the 10% energy is available from lower trophic level to higher trophic level therefore the number of individuals decreases.</p> <p>(b) The energy captured by the autotrophs cannot revert back to the solar input / energy once received by herbivores cannot come back to autotrophs</p> <p style="text-align: center;">Note: similar explanation using any two trophic levels .</p>	<p>1½</p> <p>1½</p>	3
SECTION—C			
14.	<p>(a) Since most organisms would not normally depend on being cut up to be able to reproduce.</p> <p>(b) •Plants can bear fruits and flowers much earlier than produced by sexual reproduction •Plants produced are genetically similar to the parent plant</p> <p style="text-align: right;">(Or any other)</p> <p>(c) (i) Bud develops as an outgrowth due to repeated cell division at one specific site, these buds develop into tiny individuals, and when fully mature detach from the parent body and become new independent individuals. (Marks should be awarded if a student draws a well labelled diagram)</p> <p style="text-align: center;">OR</p> <p>(c) (ii)</p> <p>(I) The filament breaks into smaller pieces or fragments and each fragment grows into new individuals.</p> <p>(II) It releases spores which germinate and eventually develops into new Rhizopus individuals.</p>	<p>1</p> <p>½ + ½</p> <p>2</p> <p>1</p> <p>1</p>	4
15.	<p>(a) $R = R_1 + R_2 + R_3$ $= 5\Omega + 10\Omega + 15\Omega$ $= 30\Omega$</p> <p>(b) $\frac{1}{R_p} = \frac{1}{R_B} + \frac{1}{R_C}$ $\frac{1}{R_p} = \frac{1}{30\Omega} + \frac{1}{60\Omega}$ $R_p = 20\Omega$</p> <p>(c) (i) $R = R_s + R_p$ $= 40\Omega + 20\Omega = 60\Omega$ $\therefore I = \frac{V}{R} = \frac{6V}{60\Omega} = \frac{1}{10} A = 0.1 A$</p>	<p>1</p> <p>½</p> <p>½</p> <p>1</p> <p>½ + ½</p>	



	OR		
	<p>(c) (ii)</p> <p>Resistance, $R = 40\Omega + 60\Omega = 100\Omega$</p> $\therefore I = \frac{V}{R} = \frac{6V}{100\Omega} = 0.06 A$	<p>1</p> <p>$\frac{1}{2} + \frac{1}{2}$</p>	<p>4</p>

* * *